

PDM5 Series

MODELS :

PDM5-1A
PDM5-500
PDM5-250



© 2022 The contents of this manual are copyright and may not be reproduced without the written permission of Tactical Power Products Pty Ltd.



Installation Manual



General

The PDM5 modules are designed for **indoor use only**.

Tactical Power Products PDM5 features ten individually fused outputs terminated to a 10 way heavy duty terminal block. A common fault relay output to signal failure of any individual circuit. This output may be used to drive DVR alarm inputs, security alarm inputs / building management systems or a local sounder / strobe to inform personnel of equipment failure.

Available in either 12vdc / 24vac, 24vdc / 24vac or 48vdc models, the use of PDM5 minimizes the likelihood of a total system shutdown in the event of a short circuit on any one single circuit run.

Featuring state-of-the-art Surface Mount Technology and 10 individual M205 1a fused protected circuits - each with an LED to indicate fuse status, Yellow high voltage 24vac status LED, the PDM5 is available with a variety of fuse ratings to suit your application - please specify 250ma, 500ma or 1a at time of order (1a supplied unless otherwise specified).

Load Current

Prior to connecting equipment to the nominated output check the device load current

Various equipment manufacturers may specify the equipment current load in Watts i.e. 12v @ 6W

A quick calculation using Ohms law can determine the load in Amps, for instance if a device nominate 6W the current can be determined $I = P \div E$, where P is power measured in watts, I is current measured in amps, and E is voltage measured in volts. Thus, the current I in amps is equal to the power P in watts divided by the voltage V in volts. Example $6W/12v=500ma$, $12W/12v =1a$
NB Only use the Watts nominated on the low voltage output never on the mains voltage.

Inrush Current

Not all manufacturers will provide the peak current (inrush current) when a device is powered, this can be critical as the inrush current may exceed the rating of the fuse and cause a circuit failure, or in the case of multiple device being powered may exceed the maximum rated current of the power supply. In which case the power supply should enter current limit or hiccup mode, where the power supply shuts down and attempts to restart. If the overload is still there which will be the case with inrush current the power supply will again enter this protection cycle and will not start leading to a total system failure.

NB Inrush current cannot be measured on standard digital multimeter due to the short duration of the cycle, this may be capable on specialised multimeter or an digital storage oscilloscope.

PCB Load Rating

Installers should ensure that total system current draw does not exceed the rating of the PCB which is rated for (10a) continuous load.

Mounting

The PDM5 series are supplied with four 3M D Stape standoff which have captive lugs when inserted into the PCB mounting hole.

Tactical series powder coated enclosures are fitted with metal 3mm x 8 mm threaded standoffs to suit PDM module and flush mount 3 mm root nuts to mount power modules and are designed to accommodate various SLA batteries check with your supplier.

Settings

J -1 Voltage Selection

All models are factory set for 24vac operation header shunt on pins 2 & 3. For dc operation change header shut pins to 1 & 2.

LAYOUT

Settings Cont.

X4 Common Fault Relay

PDM5 incorporates an onboard common fault relay (SPDT) which activates when any of the fuses fail NC,CO,NO.

Outputs

Output terminals 1-10 are fitted default with 1a M205 fuses.

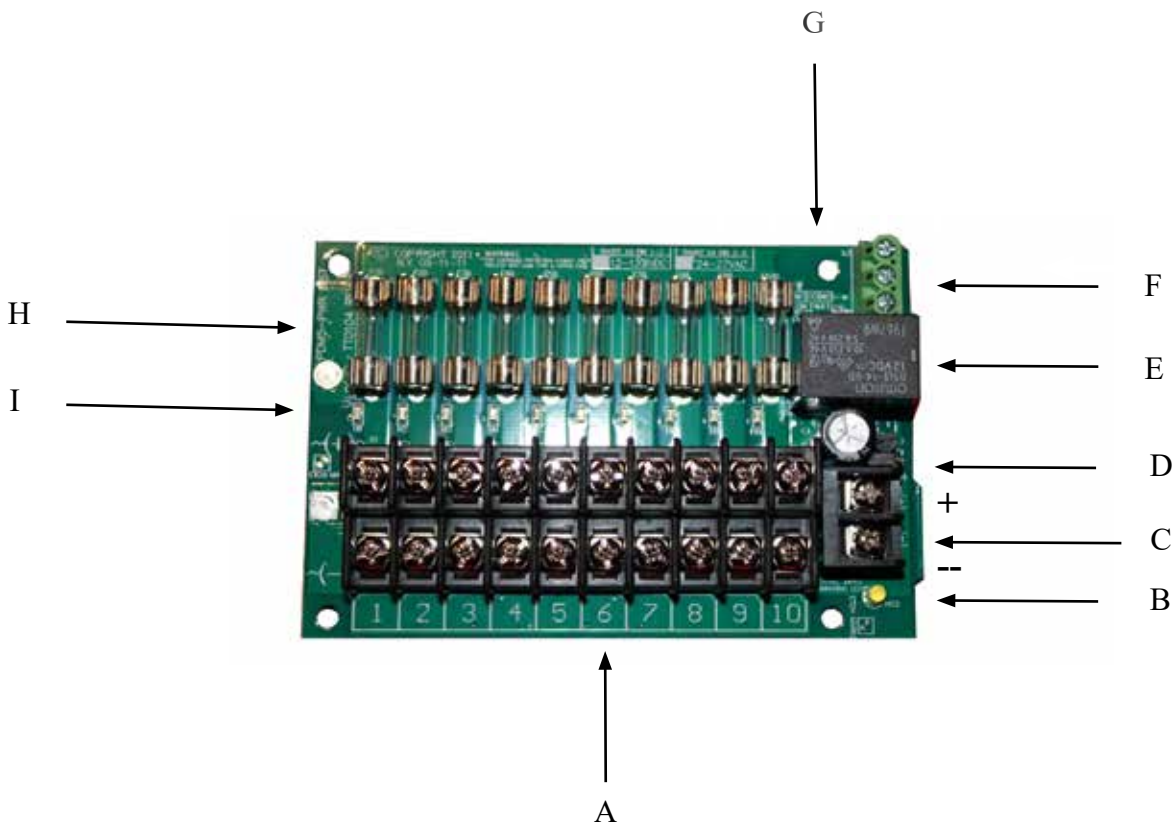

A	Output Terminals	B	24vac yellow LED indications
C	Voltage Input model dependant 12vdc or 24vdc	D	ac-dc Header shunt 1 & 2 =dc Input 2 & 3 = ac Input
E	Common fault relay	F	Common Fault relay SPDT (NC-COM-NO)
G	Mounting hole	H	10 x Individual Circuit Fuses 1a M205
I	Circuit Status LEDs (green) under fuses (H1-H10)	J	Supplied with 3M mounting feet

Specifications :

(In the interests of product improvement, Tactical reserves the right to change specifications without notice)

PDM5	
Input Voltage	12vdc / 24vac, 24vdc & 48vdc model dependant
No: of Outputs	10
LED's	Output Fuse Status Green / 24vac High Voltage Yellow / Common Fault Trip Relay Red
Dimensions	111 L x 75 W x 25 H mm
Mounting	4 x 3M Adhesive Feet.
Max Load Current	10A Continuous
Common Fault Relay	6a / 30vdc SPDT

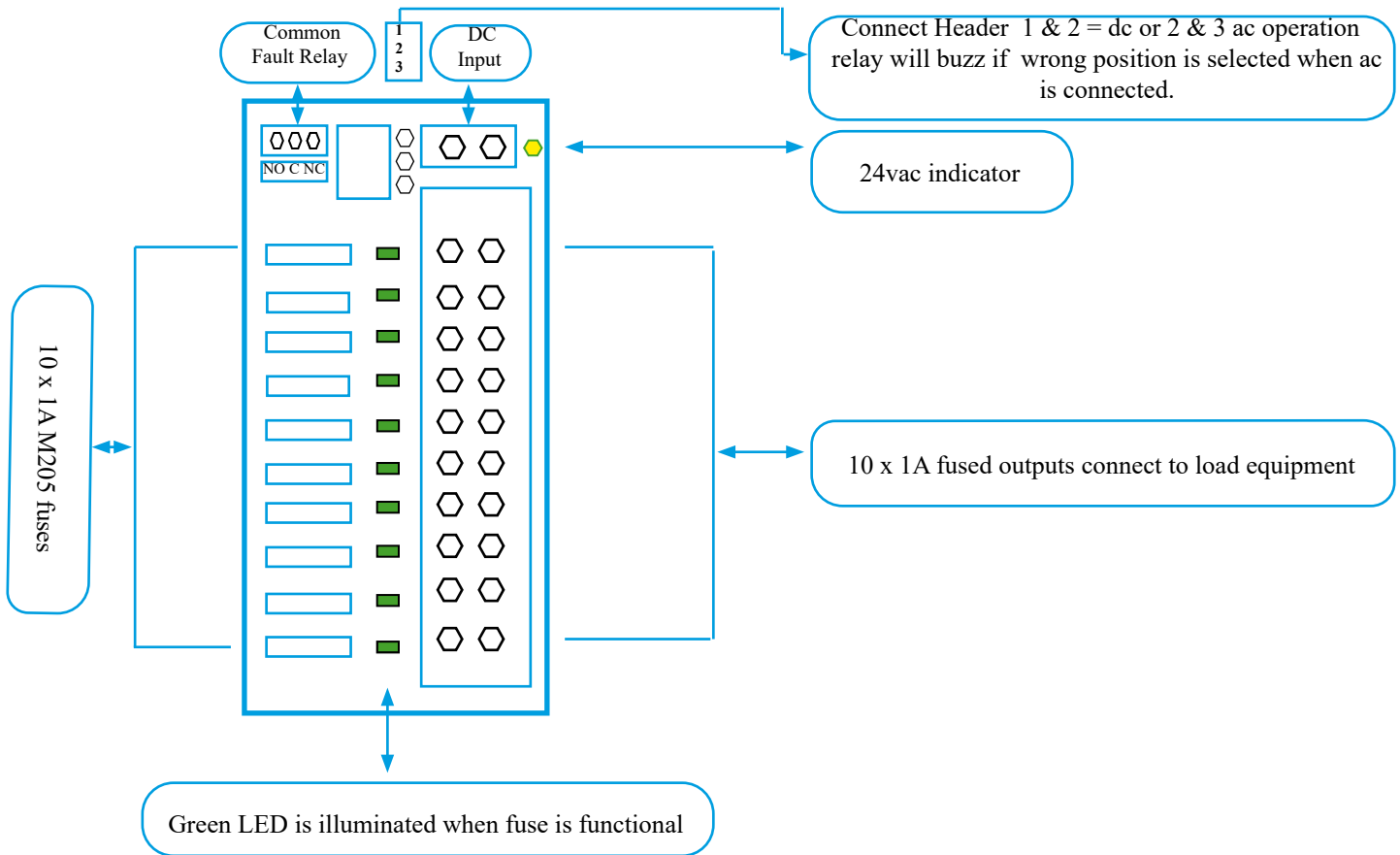

Securing Your Power Needs[®]
Now and into the Future ...

www.tacpower.com.au

